

THERMODUR – Lightweight Concrete Walls



The problem:

- Individuality in architecture always results in higher cost. This often leads to plain and simple design of the architects and designers.

The solution: THERMODUR exterior walls

THERMODUR wall elements are not bound to any grid dimension.

- Bevel cuts, pass plates, cutouts for windows and doors including lintel reinforcements (without extra charge)
- Large format wall elements up to 11 x 3 m in any dimension (without extra charge)
- Self-supporting with only minimum substructure necessary
- The bottom elements can be designed as foundation with or without frost protection
- Rain proof plaster (without extra charge)
- Design assistance (without extra charge)
- Various special elements such as round cutouts or designed entrance areas (optional)

Your Advantage:

- More creative freedom
- Simple work flow on site, according to tight schedules, reduced coordination effort for the site manager.
- Reliability (more than 5,000 projects completed)
- The builder saves time and money



Thermal-, sound-, and fire protection ...

Natural concrete: Excellent thermal protection. Excellent sound protection. Fire-proof.

Thermal protection pays off. It becomes increasingly important for architects, designers and builders to handle energy related design issues with great care. Requirements of construction physics for exterior walls have increased. Wall elements made of light weight concrete provide excellent thermal insulation criteria for both summer and winter temperatures.

Lightweight concrete provides best performance in sound protection, sound damping and sound absorption. Lightweight concrete is fire-proof. It is certified as a fire-proof building material. THERMODUR wall elements can be installed as firewalls.

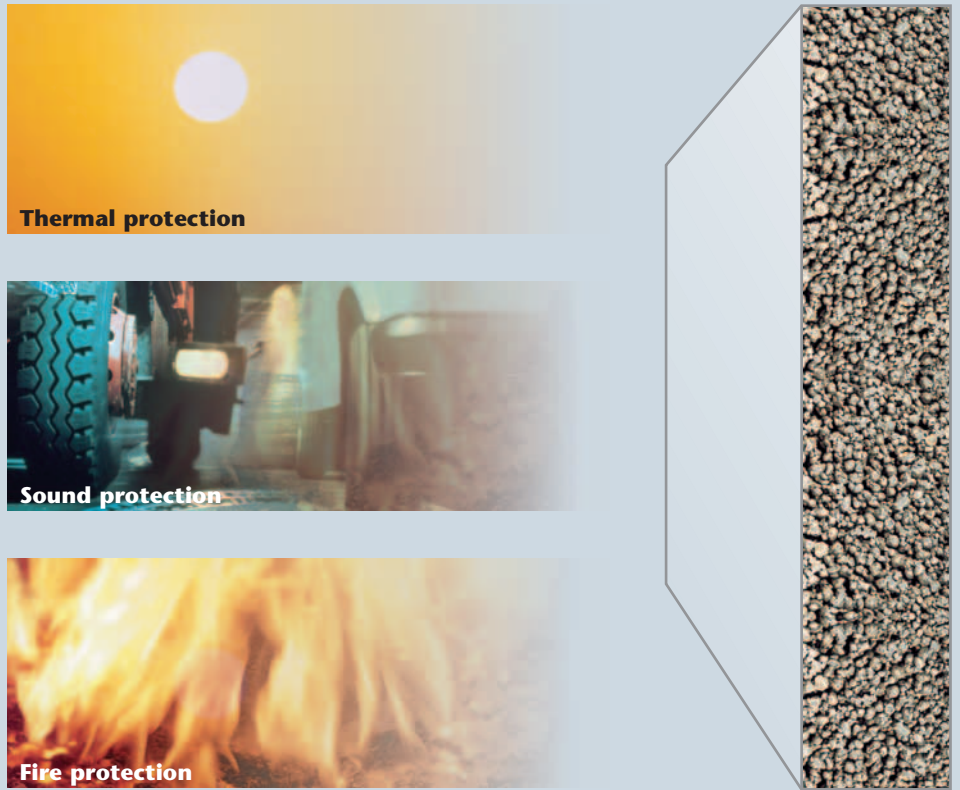

THERMODUR Thermal Protection

Thermal accumulation means saving energy.

The fine air pores within the lightweight concrete accumulate thermal heat and ensure a perfect room climate at the same time.

An additional core insulation can even optimise the performance of lightweight concrete regarding thermal insulation.

thickness d [cm]	heat transfer coefficient u [W/m ² K]			
	without core insulation	with core insulation	super core insulation	firewall with core insul.
20,0	0,96	0,65		
22,5	0,87	0,61		0,65
25,0	0,79	0,53		0,58
27,5	0,73	0,47		0,55
30,0	0,67	0,42	0,35	0,52
32,5	0,62	0,40		0,49
35,0	0,58	0,36	0,32	0,46
37,5			0,28	
40,0			0,25	

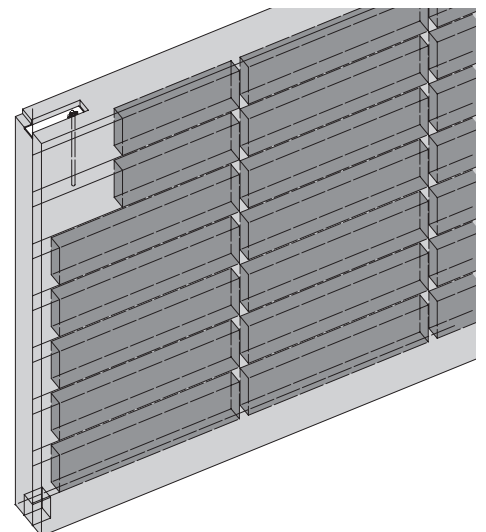

... best characteristics of construction physics

THERMODUR Sound Protection

wall thickness d [cm]	moulded density class	material weight [kg/m ²]	sound insulation factor R'w [dB]
20	0,8	160,50	42
	1,0	198,50	44
	1,2	227,00	46
	1,4	265,00	48
25	0,8	198,00	44
	1,0	246,00	47 49 *)
	1,2	282,00	48
	1,4	330,00	50
30	0,8	235,50	46
	1,0	293,50	49 52 *)
	1,2	337,00	51
	1,4	395,00	52
35	0,8	273,00	48
	1,0	341,00	51
	1,2	392,00	52
	1,4	460,00	54

Sound damping

Pumice stone scores excellent results in the absorption of interior and exterior sound.

Air conduction of noise will be effectively shielded in both directions, exterior to interior and vice versa.

*) According to test report of RWTÜV

THERMODUR Fire Protection

No Danger of Fire

Once the decision has been made for THERMODUR wall elements, no additional attention has to be paid regarding fire protection of the walls. THERMODUR wall elements are fire-proof and can be used as firewalls class A1 according to DIN 4102.

The certificate proves THERMODUR wall elements as firewalls.



A fatal fire destroyed the factory floor. Thanks to the THERMODUR firewall the bureaus remained unaffected.



General certificate of site inspection:

Certification No.: P - 3314/0901 - MPA BS

Issue: Supporting, sealed lightweight concrete wall elements, vertically or horizontally fixed, with the protection class F 90 and F 180 according to DIN 4102-2 or as a firewall according to DIN 4102-3.

Assigned by: THERMODUR Wandelemente GmbH & Co KG
In Metzlerskaul 20
D-56567 Neuwied

Issue Date: 22.12.2003

Expiration Date: 22.12.2008

Certification authority: Materialprüfanstalt Braunschweig Institut für Baustoffe, Massivbau und Brandschutz
Technische Universität Braunschweig
Beethovenstraße 52
D-38106 Braunschweig

As a result of the general certificate of site inspection the above mentioned object can be used according to the building regulations.

THERMODUR – Advantages at a glance

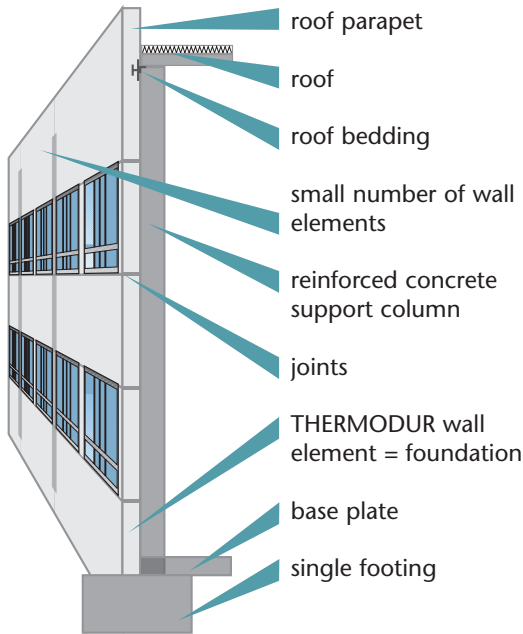

Flexible design – balanced appearance

With THERMODUR wall elements there is no limit to your planning creativity. Architecture will no longer be restricted by given grid measurements.

Your advantages:

- + Grids of max. 11 x 3 m for wide centre distances
- + THERMODUR wall elements can be used as foundation
- + No limitation in the measurements of windows, doors and gates
- + No need for adjustments on site
- + Special shapes prefabricated in the factory
- + Roof-bedding prefabricated in the factory
- + Substructures, door frames, etc. are unnecessary due to

high stability and large format of the wall elements

- + THERMODUR wall elements are provided with an outside rain proof plaster
- + No roof parapet constructions necessary
- + THERMODUR wall elements comply with F-90-requirements of fire protection and can be used as firewalls

THERMODUR wall elements provide best performance in sound protection, sound insulation and sound absorption. As a result they are used for projects, where good acoustic is of importance. Suitable for gyms, factories, etc. THERMODUR wall elements provide comparable thermal protection ratings as aerated concrete.

